



small enough to care, big enough to handle

Here at Valland we are committed to the design and manufacture of high quality and tailor-made On/Off Valves.

Our main market is the Oil & Gas exploration and production sectors, including subsea and transmission, and other special service industrial application.

Our Company was established in 2006 by people that have been working in the valve business since more than 30 years and have engineered valves which represent the most updated solutions for the severe offshore environment and subsea application.

Nowadays Valland is best known for its focus on the clients' needs, achieving outstanding performances by our continuous improvement and technical skills.

quality assurance

Our Quality Management System has been implemented according to ISO 9001:2015 and regulated by strict internal procedure for quality control and quality assurance.

Since 2008 we have achieved and maintained three API monograms: API 6A, API 6D, API 6DSS.

This Program is subject to continuous improvement by review and audit by internal personnel and authorized agencies.

We also satisfy all the provisions of the European Pressure Equipment Directive.

mission

To bring customized solutions that allow the full realization of the client's vision, to the highest level of quality and reliability.

To foster trust from clients through consistent good results.

To build and maintain a network throughout the supply chain of trust and respect, that ensures stability and continuity for all involved.

To give value to the environment and society where we operate, so that they are enriched and enrich the companies that operate in our territory.

vision

To set the standard worldwide for reliable customized solutions; to be a model of trustful and fruitful co-operation with the whole supply chain and local environments and societies.

To be present worldwide as a locally integrated, high standard, reliable and trustworthy reference point for our products and all of the services thereof.

side entry trunnion ball valve

model A11
compact design



side entry trunnion ball valve- A11 compact design

main features

Applicable standards	API 6D and API 6A Design according to ASME B16.34 or ASME VIII Div. 1 & 2
Pressure Class Range	ANSI Class 150 lbs. to 4500 lbs API6A Class 3000 PSI to 20000 PSI
Size Range	API 6D, API 6DSS - from ½" to 42" API 6A - from 1 13/16" to 13 5/8"
Ends design	Flanged (RF – RTJ) – ASME B16.5, ASME B16.47 or MSS SP-44 Flanged (6B – 6BX) – API 6A Compact (i.e. Norsok Standard L-005) Butt-Weld (ASME B16.25) and/or Butt-Weld+Pipe Hubbed according to client Clamp Special client's requirements to achieve the shortest face to face dimension
Body Design	Two or Three Pieces
Closure Design	Bolted Closure or Fully welded
Ball support	Trunnion (small sizes < 4") – Support Plates
Seat design	Floating Self-Relieving – Floating Double Piston Effect Soft Sealing – Metal to Metal (c/w hardfacing)
Valve operation	Manual: Lever or Gearbox Actuated: Pneumatic / Hydraulic / Electric / Electro-Hydraulic
Available Materials	CS, LTCS, SS, Duplex SS, Super Duplex SS, 6Mo, Inconel, Incoloy, Hastelloy, Monel, Titanium NACE MR0175 according to client request
Additional Features	Double Block and Bleed, Double Isolation Barrier (DIB), Anti Blowout Stem, Antistatic Device
Testing and Certification	Testing: Hydrostatic, High Pressure Gas, Pneumatic and Functional API 598 – API 6D - API 6A PSL3G, API 6A PR2 & Endurance Fire testing: API 6FA, API 607, BS 6755 part 2, ISO 10497 Fugitive Emission Test: ISO 15848 – 1 & 2 SIL Certificate up to SIL 3 PED 2014/68/UE Mod.H

side entry trunnion ball valve

model A11



side entry trunnion ball valve- A11

main features

Applicable standards	API 6D or API 6A Design according to ASME B16.34 or ASME VIII Div. 1 & 2
Pressure Class Range	ANSI Class 150 lbs. to 4500 lbs. API6A Class 3000 PSI to 20000 PSI
Size Range	API 6D - from ½" to 42" API 6A from 1 13/16" to 13 5/8"
Ends design	Flanged (RF – RTJ) – ASME B16.5 or ASME B16.47 Flanged (6B – 6BX) – API 6A Compact (Norsok Standard L-005) Butt-Weld (ASME B16.25) and/or Butt-Weld+Pipe Hubbed according to client Clamp
Body Design	Two or Three Pieces
Closure Design	Bolted Closure or Fully welded
Ball support	Trunnion (small sizes < 4") – Support Plates
Seat design	Floating Self-Relieving – Floating Double Piston Effect Soft Sealing – Metal to Metal (Tungsten Carbide Coating)
Valve operation	Manual: Lever or Gearbox Actuated: Pneumatic / Hydraulic / Electric / Electro-Hydraulic
Available Materials	CS, LTCS, SS, Duplex SS, Super Duplex SS, 6Mo, Inconel, Incoloy, Hastelloy, Monel, Titanium NACE MR0175 according to client request
Additional Features	Double Block and Bleed, Anti Blowout Stem, Antistatic Device
Testing and Certification	Testing: Hydrostatic, High Pressure Gas, Pneumatic and Functional API 598 – API 6A PSL3G, API 6A PR2 & Endurance Fire testing: API 6FA, API 607, BS 6755 part 2 Fugitive Emission Test: ISO 15848 – 1 & 2 SIL Certificate up to SIL 3 PED 2014/68/UE Mod.H

side entry floating ball valve

model A21

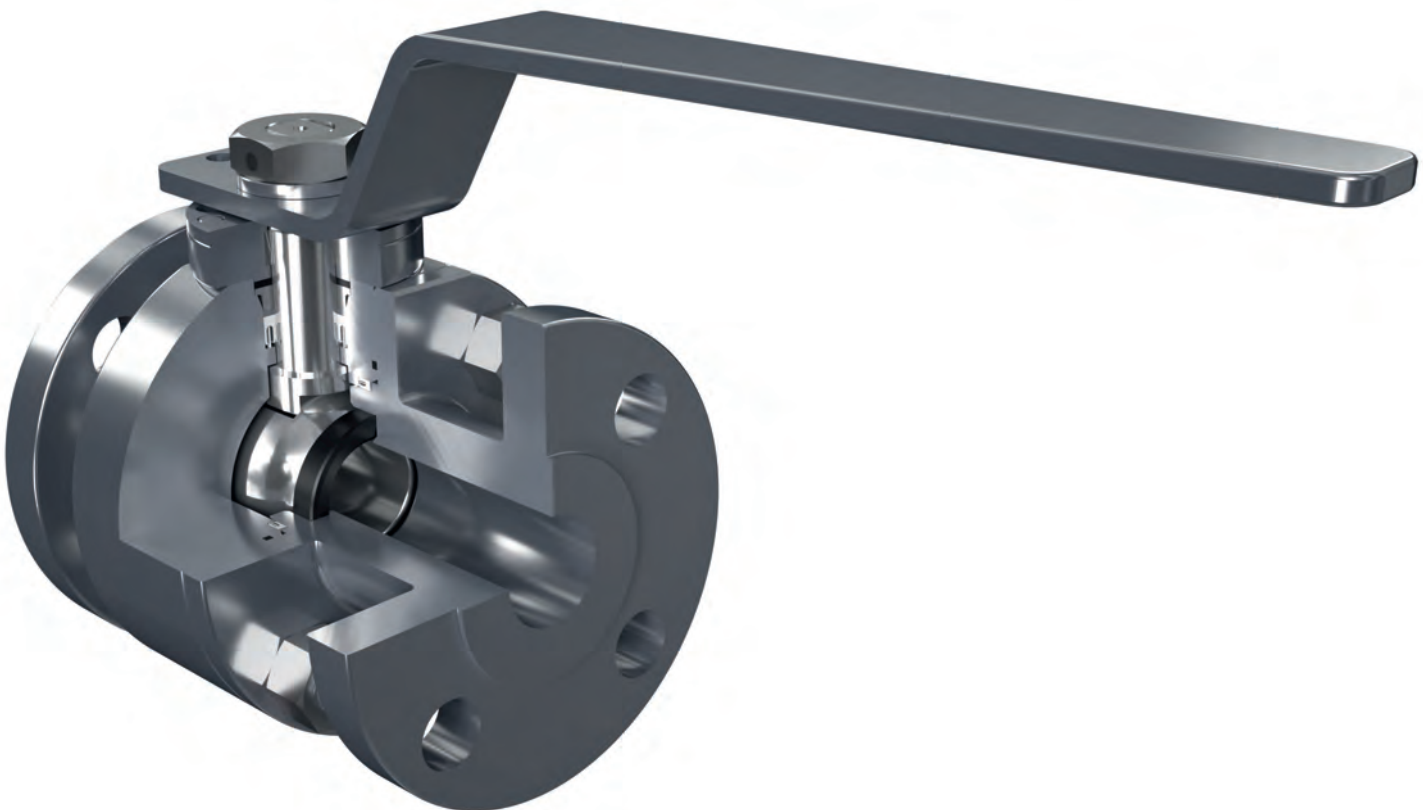

side entry floating ball valve- A21

main features

Applicable standards	API 6D Design according to ASME B16.34 or ASME VIII Div. 1 & 2
Pressure Class Range	ANSI Class 150 lbs. to 1500 lbs.
Size Range	From ½" to 8"
Ends design	Flanged (RF – RTJ) – ASME B16.5, ASME B16.47 or MSS SP-44 Compact (i.e. Norsok Standard L-005) Butt-Weld (ASME B16.25) and/or Butt-Weld+Pipe Hubbed according to client Clamp Special client's requirements
Body Design	Two or Three Pieces
Closure Design	Bolted Closure
Seat design	Soft Sealing – Metal to Metal (c/w hardfacing)
Valve operation	Manual: Lever or Gearbox
Available Materials	CS, LTCS, SS, Duplex SS, Super Duplex SS, 6Mo, Inconel, Incoloy, Hastelloy, Monel, Titanium NACE MR0175 according to client request
Additional Features	Anti Blowout Stem, Antistatic Device
Testing and Certification	Testing: Hydrostatic, High Pressure Gas, Pneumatic and Functional API 598 – API 6D Fire testing: API 6FA, API 607, BS 6755 part 2, ISO 10497 Fugitive Emission Test: ISO 15848 – 1 & 2 PED 2014/68/UE Mod.H

top entry ball valve

model A31

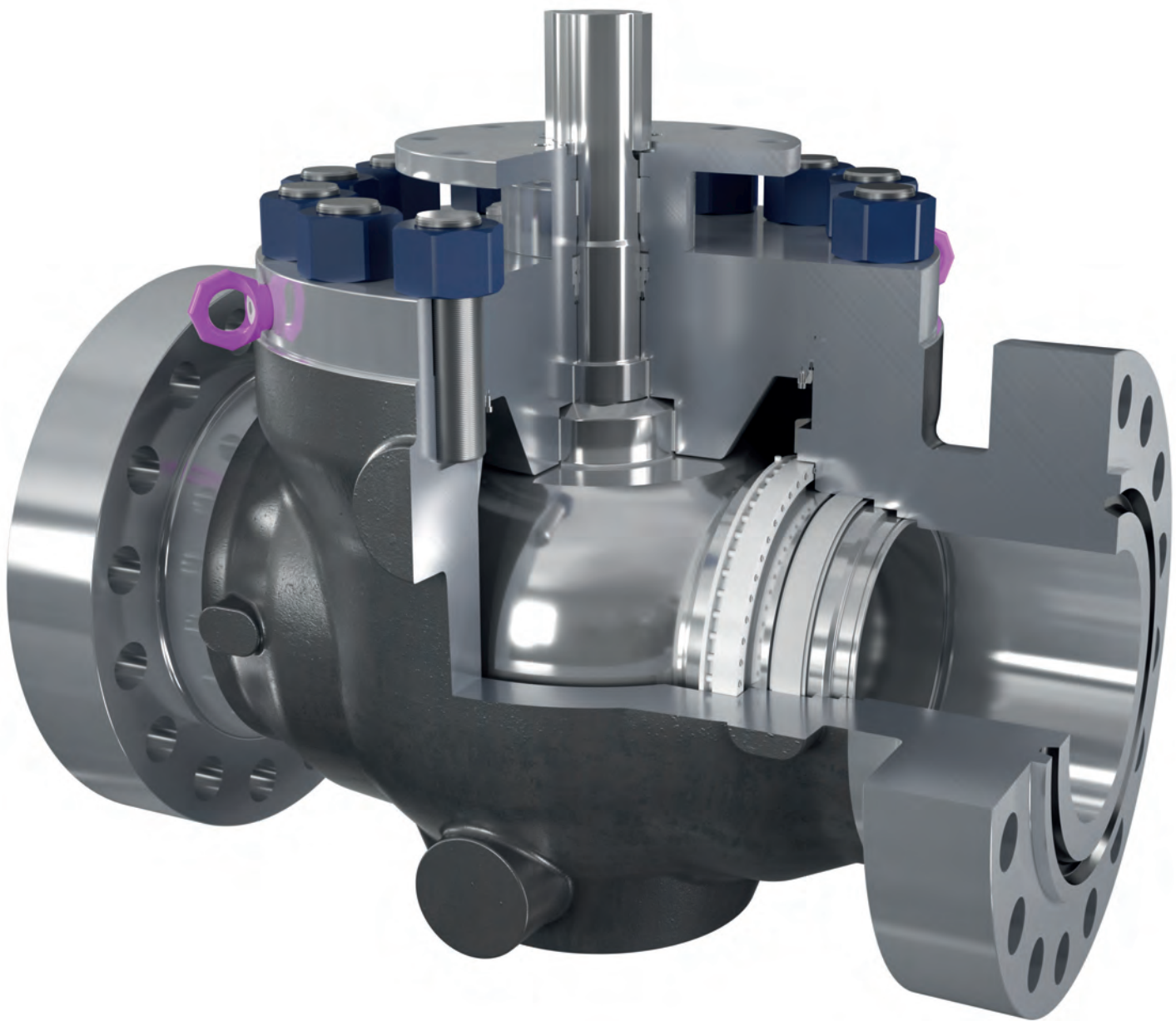

top entry ball valve- A31

main features

Applicable standards	API 6D and API 6A Design according to ASME B16.34 or ASME VIII Div. 1 & 2
Pressure Class Range	ANSI Class 150 lbs. to 4500 lbs. API6A Class 3000 PSI to 20000 PSI
Size Range	API 6D - from ½" to 42" API 6A - from 1 13/16" to 13 5/8"
Ends design	Flanged (RF – RTJ) – ASME B16.5, ASME B16.47 or MSS SP-44 Flanged (6B – 6BX) – API 6A Compact (i.e. Norsok Standard L-005) Butt-Weld (ASME B16.25) and/or Butt-Weld+Pipe Hubbed according to client Clamp Special client's requirements
Body Design	Single Piece
Bonnet Design	Bolted Bonnet or Pressure seal
Seat design	Floating Self-Relieving – Floating Double Piston Effect Soft Sealing – Metal to Metal (c/w hardfacing)
Valve operation	Manual: Lever or Gearbox Actuated: Pneumatic / Hydraulic / Electric / Electro-Hydraulic
Available Materials	CS, LTCS, SS, Duplex SS, Super Duplex SS, 6Mo, Inconel, Incoloy, Hastelloy, Monel, Titanium NACE MR0175 according to client request
Additional Features	Double Block and Bleed, Double Isolation Barrier (DIB), Anti Blowout Stem, Antistatic Device
Testing and Certification	Testing: Hydrostatic, High Pressure Gas, Pneumatic and Functional API 598 – API 6D - API 6A PSL3G, API 6A PR2 & Endurance Fire testing: API 6FA, API 607, BS 6755 part 2, ISO 10497 Fugitive Emission Test: ISO 15848 – 1 & 2 SIL Certificate up to SIL 3 PED 2014/68/UE Mod.H

side entry trunnion modular DBB ball valve

model A41

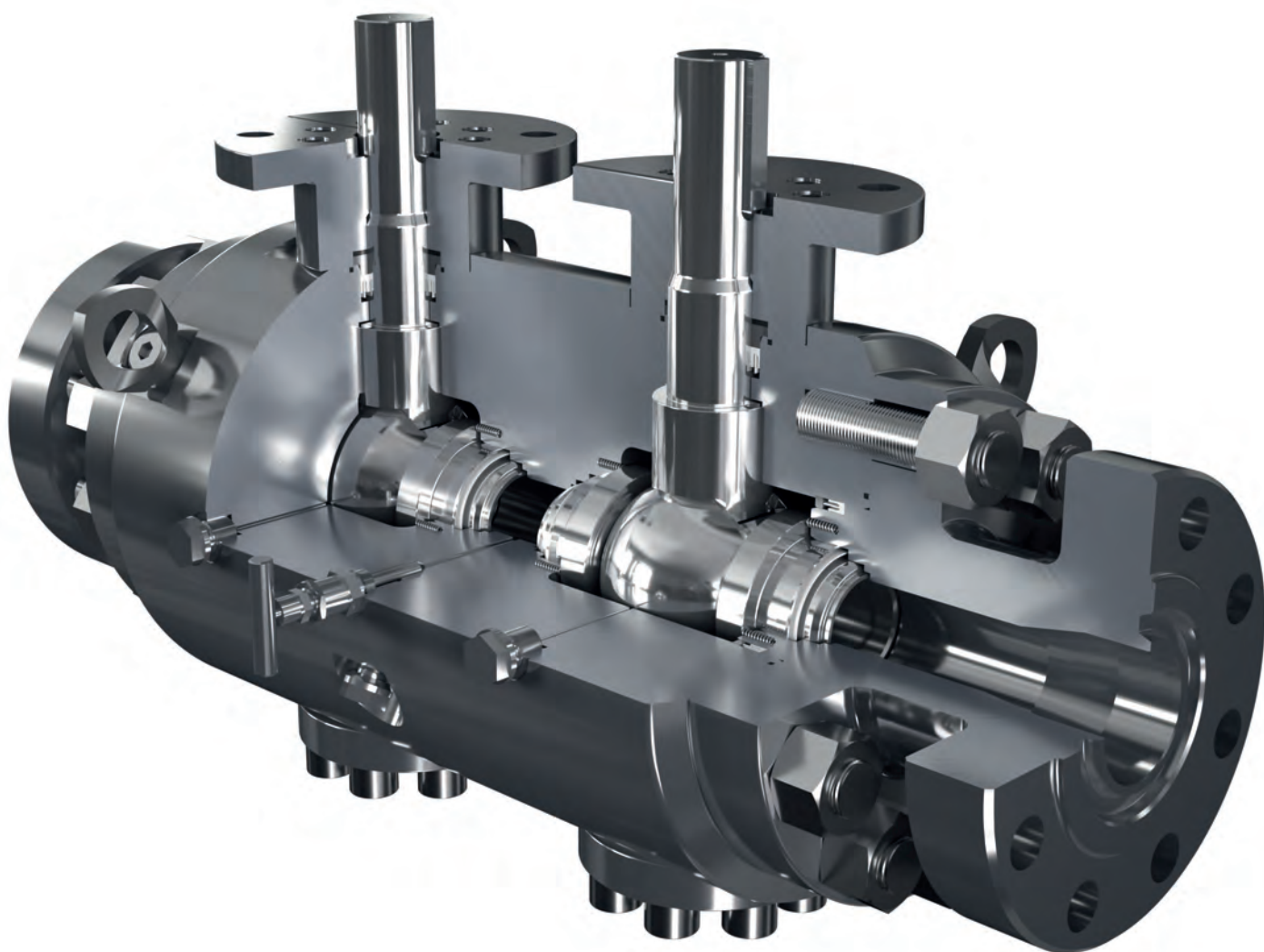

side entry trunnion modular DBB ball valve- A41

main features

Applicable standards	API 6D and API 6A Design according to ASME B16.34 or ASME VIII Div. 1 & 2
Pressure Class Range	ANSI Class 150 lbs. to 4500 lbs. API6A Class 3000 PSI to 20000 PSI
Size Range	API 6D - from ½" to 42" API 6A - from 1 13/16" to 13 5/8"
Ends design	Flanged (RF – RTJ) – ASME B16.5, ASME B16.47 or MSS SP-44 Flanged (6B – 6BX) – API 6A Compact (i.e. Norsok Standard L-005) Butt-Weld (ASME B16.25) and/or Butt-Weld+Pipe Hubbed according to client Clamp Special client's requirements
Body Design	Three Pieces
Closure Design	Bolted Closure or Fully welded
Needle Design	Bolted Bonnet, Swivelling type plus hardfacing on main valve body sealing area (upon request)
Ball support	Trunnion (small sizes < 4") – Support Plates
Seat design	Floating Self-Relieving – Floating Double Piston Effect Soft Sealing – Metal to Metal (c/w hardfacing)
Valve operation	Manual: Lever or Gearbox Actuated: Pneumatic / Hydraulic / Electric / Electro-Hydraulic
Available Materials	CS, LTCS, SS, Duplex SS, Super Duplex SS, 6Mo, Inconel, Incoloy, Hastelloy, Monel, Titanium NACE MR0175 according to client request
Additional Features	Double Block and Bleed, Anti Blowout Stem, Antistatic Device
Testing and Certification	Testing: Hydrostatic, High Pressure Gas, Pneumatic and Functional API 598 – API 6D - API 6A PSL3G, API 6A PR2 & Endurance Fire testing: API 6FA, API 607, BS 6755 part 2, ISO 10497 Fugitive Emission Test: ISO 15848 – 1 & 2 SIL Certificate up to SIL 3 PED 2014/68/UE Mod.H

side entry floating modular DBB ball valve

model A42

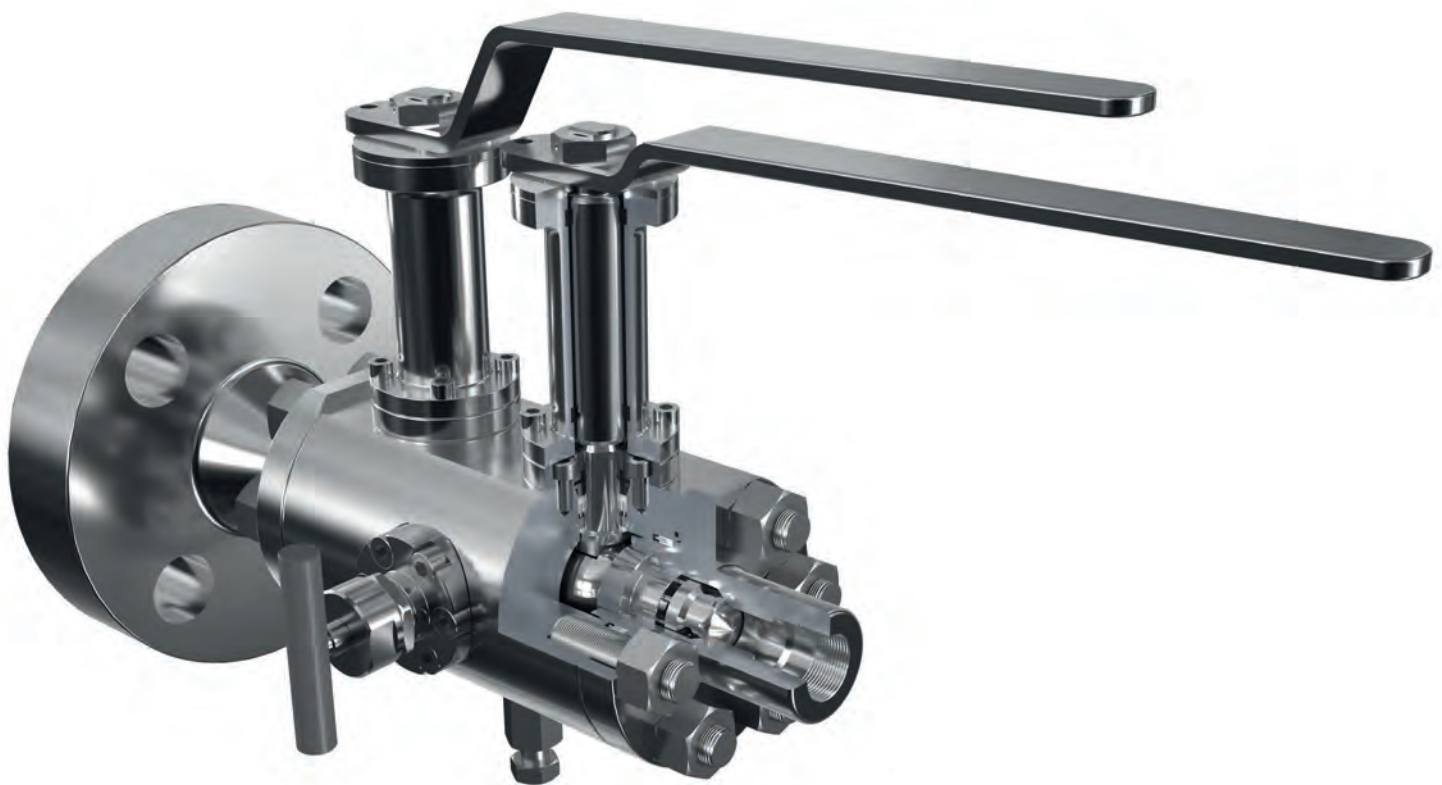

side entry floating modular DBB ball valve- A42

main features

Applicable standards	API 6D Design according to ASME B16.34 or ASME VIII Div. 1 & 2
Pressure Class Range	ANSI Class 150 lbs. to 4500 lbs.
Size Range	From ½" to 8"
Ends design	Flanged (RF – RTJ) – ASME B16.5, ASME B16.47 or MSS SP-44 Compact (i.e. Norsok Standard L-005) Butt-Weld (ASME B16.25) and/or Butt-Weld+Pipe Hubbed according to client Clamp Special client's requirements
Body Design	Three Pieces
Closure Design	Bolted Closure
Needle Design	Bolted Bonnet, Swivelling type plus hardfacing on main valve body sealing area (upon request)
Seat design	Soft Sealing – Metal to Metal (c/w hardfacing)
Valve operation	Manual: Lever or Gearbox
Available Materials	CS, LTCS, SS, Duplex SS, Super Duplex SS, 6Mo, Inconel, Incoloy, Hastelloy, Monel, Titanium NACE MR0175 according to client request
Additional Features	Anti Blowout Stem, Antistatic Device, Extended Stem – Extended Lever
Testing and Certification	Testing: Hydrostatic, High Pressure Gas, Pneumatic and Functional API 598 – API 6D Fire testing: API 6FA, API 607, BS 6755 part 2, ISO 10497 Fugitive Emission Test: ISO 15848 – 1 & 2 PED 2014/68/UE Mod.H

subsea trunnion ball valve

model A61



subsea trunnion ball valve- A61

main features

Applicable standards	API 6DSS and API 6A Design according to ASME B16.34 or ASME VIII Div. 1 & 2
Pressure Class Range	ANSI Class 150 lbs. to 4500 lbs. API6A Class 3000 PSI to 20000 PSI
Size Range	API 6DSS - from ½" to 42" API 6A from 1 13/16" to 13 5/8"
Ends design	Flanged (RF – RTJ) – ASME B16.5, ASME B16.47 or MSS SP-44 Flanged (6B – 6BX) – API 6A Compact (i.e. Norsok Standard L-005) Butt-Weld (ASME B16.25) and/or Butt-Weld+Pipe Hubbed according to client Clamp Special client's requirements
Body Design	Side Entry Two / Three Pieces – Top Entry
Closure Design	Bolted Closure or Fully welded
Ball support	Trunnion (small sizes < 4") – Support Plates
Seat design	Floating Self-Relieving – Floating Double Piston Effect Soft Sealing – Metal to Metal (c/w hardfacing)
Valve operation	Manual: Lever, Gearbox + Handwheel (Shallow Water), Gearbox + ROV (Deep sea) Actuated: Hydraulic Direct ROV receptacle
Available Materials	CS, LTCS, SS, Duplex SS, Super Duplex SS, 6Mo, Inconel, Incoloy, Hastelloy, Monel, Titanium NACE MR0175 according to client request
Additional Features	Double Block and Bleed, Double Isolation Barrier (DIB), Anti Blowout Stem, Antistatic Device, Redundant Sealing Barrier for Fluid + Environmental Seal Up to 50 years working life (without maintenance) design
Testing and Certification	Testing: Hydrostatic, High Pressure Gas, Pneumatic and Functional Localized Hyperbaric / Full Hyperbaric Test API 598 – API 6D - API 6A PSL3G, API 6A PR2 & Endurance Fire testing: API 6FA, API 607, BS 6755 part 2, ISO 10497 Fugitive Emission Test: ISO 15848 – 1 & 2 Bending test SIL Certificate up to SIL 3 PED 2014/68/UE Mod.H

side entry trunnion cryogenic ball valve

model A71

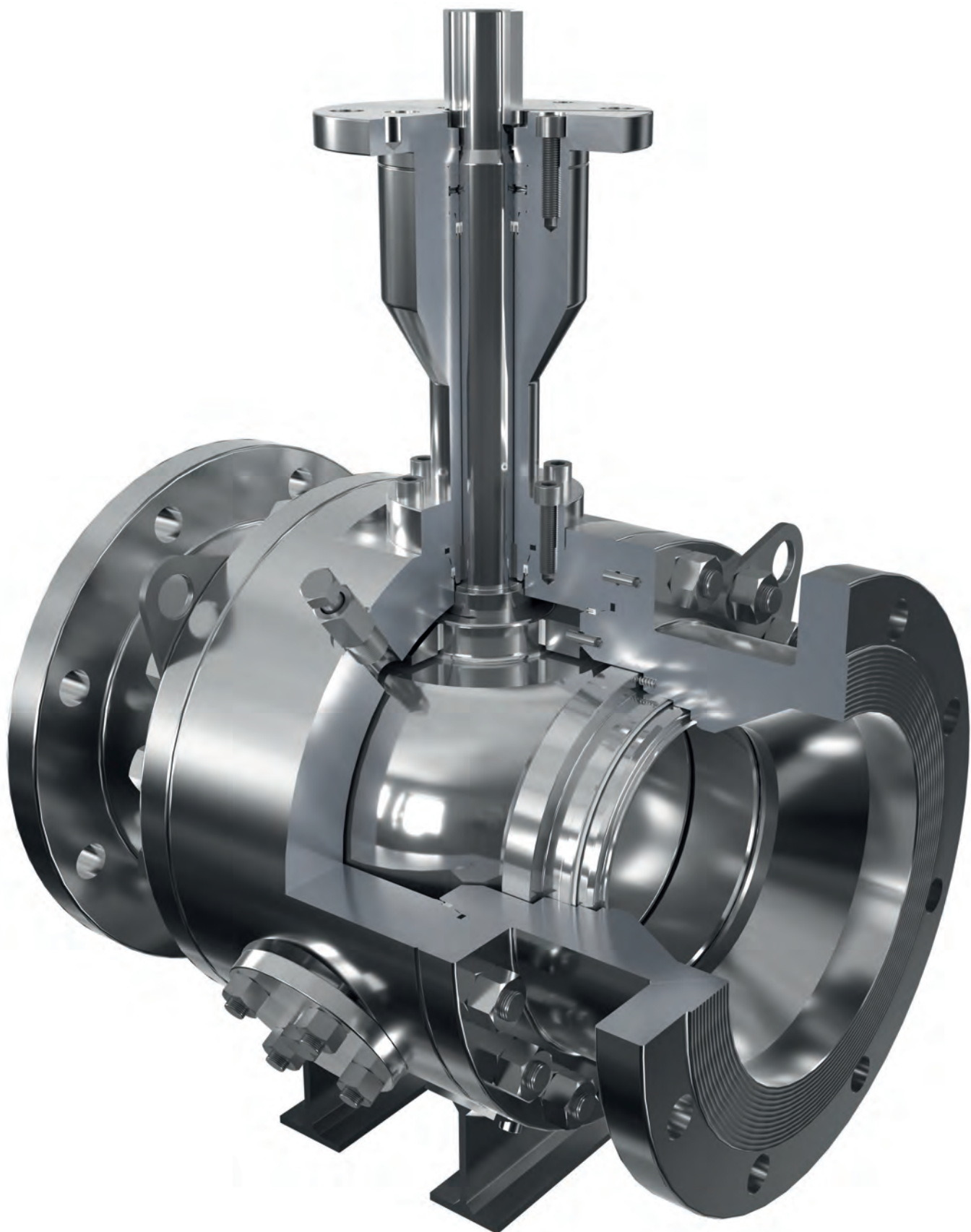

side entry trunnion cryogenic ball valve- A71

main features

Applicable standards	API 6D and API 6A Design according to ASME B16.34 or ASME VIII Div. 1 & 2
Pressure Class Range	ANSI Class 150 lbs. to 4500 lbs. API6A Class 3000 PSI to 20000 PSI
Size Range	API 6D - from ½" to 42" API 6A - from 1 13/16" to 13 5/8"
Ends design	Flanged (RF – RTJ) – ASME B16.5, ASME B16.47 or MSS SP-44 Flanged (6B – 6BX) – API 6A Compact (i.e. Norsok Standard L-005) Butt-Weld (ASME B16.25) and/or Butt-Weld+Pipe Hubbed according to client Clamp Special client's requirements
Body Design	Two or Three Pieces
Closure Design	Bolted Closure or Fully welded
Ball support	Trunnion (small sizes < 4") – Support Plates
Seat design	Floating Self-Relieving – Floating Double Piston Effect Soft Sealing – Metal to Metal (c/w hardfacing)
Valve operation	Manual: Lever or Gearbox Actuated: Pneumatic / Hydraulic / Electric / Electro-Hydraulic
Available Materials	CS, LTCS, SS, Duplex SS, Super Duplex SS, 6Mo, Inconel, Incoloy, Hastelloy, Monel, Titanium NACE MR0175 according to client request
Additional Features	Double Block and Bleed, Double Isolation Barrier (DIB), Anti Blowout Stem, Antistatic Device, Extended Stem, Extended Lever
Testing and Certification	Testing: Hydrostatic, High Pressure Gas, Pneumatic and Functional API 598 – API 6D - API 6A PSL3G, API 6A PR2 & Endurance Fire testing: API 6FA, API 607, BS 6755 part 2, ISO 10497 Fugitive Emission Test: ISO 15848 – 1 & 2 SIL Certificate up to SIL 3 PED 2014/68/UE Mod.H

side entry floating high temperature ball valve

model A81



side entry floating high temperature ball valve- A81

main features

Applicable standards	API 6D Design according to ASME B16.34 or ASME VIII Div. 1 & 2
Pressure Class Range	ANSI Class 150 lbs. to 1500 lbs.
Size Range	From ½" to 8"
Ends design	Flanged (RF – RTJ) – ASME B16.5, ASME B16.47 or MSS SP-44 Compact (i.e. Norsok Standard L-005) Butt-Weld (ASME B16.25) and/or Butt-Weld+Pipe Hubbed according to client Clamp Special client's requirements
Body Design	Two or Three Pieces
Closure Design	Bolted Closure
Seat design	Metal to Metal (special Chromium Carbide Coating)
Valve operation	Manual: Lever or Gearbox
Available Materials	CS, LTCS, SS, Duplex SS, Super Duplex SS, 6Mo, Inconel, Incoloy, Hastelloy, Monel, Titanium NACE MR0175 according to client request
Additional Features	Anti Blowout Stem, Antistatic Device, Extended Stem
Testing and Certification	Testing: Hydrostatic, High Pressure Gas, Pneumatic and Functional API 598 – API 6D Fire testing: API 6FA, API 607, BS 6755 part 2, ISO 10497 Fugitive Emission Test: ISO 15848 – 1 & 2 PED 2014/68/UE Mod.H

parallel slide/slab gate valve

model B11

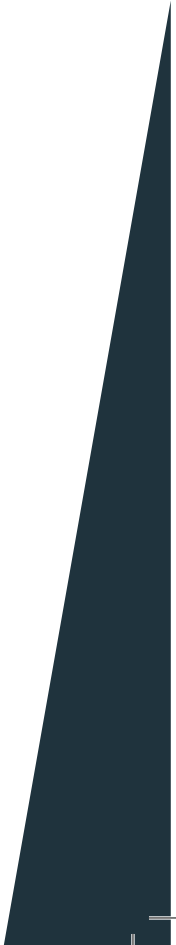
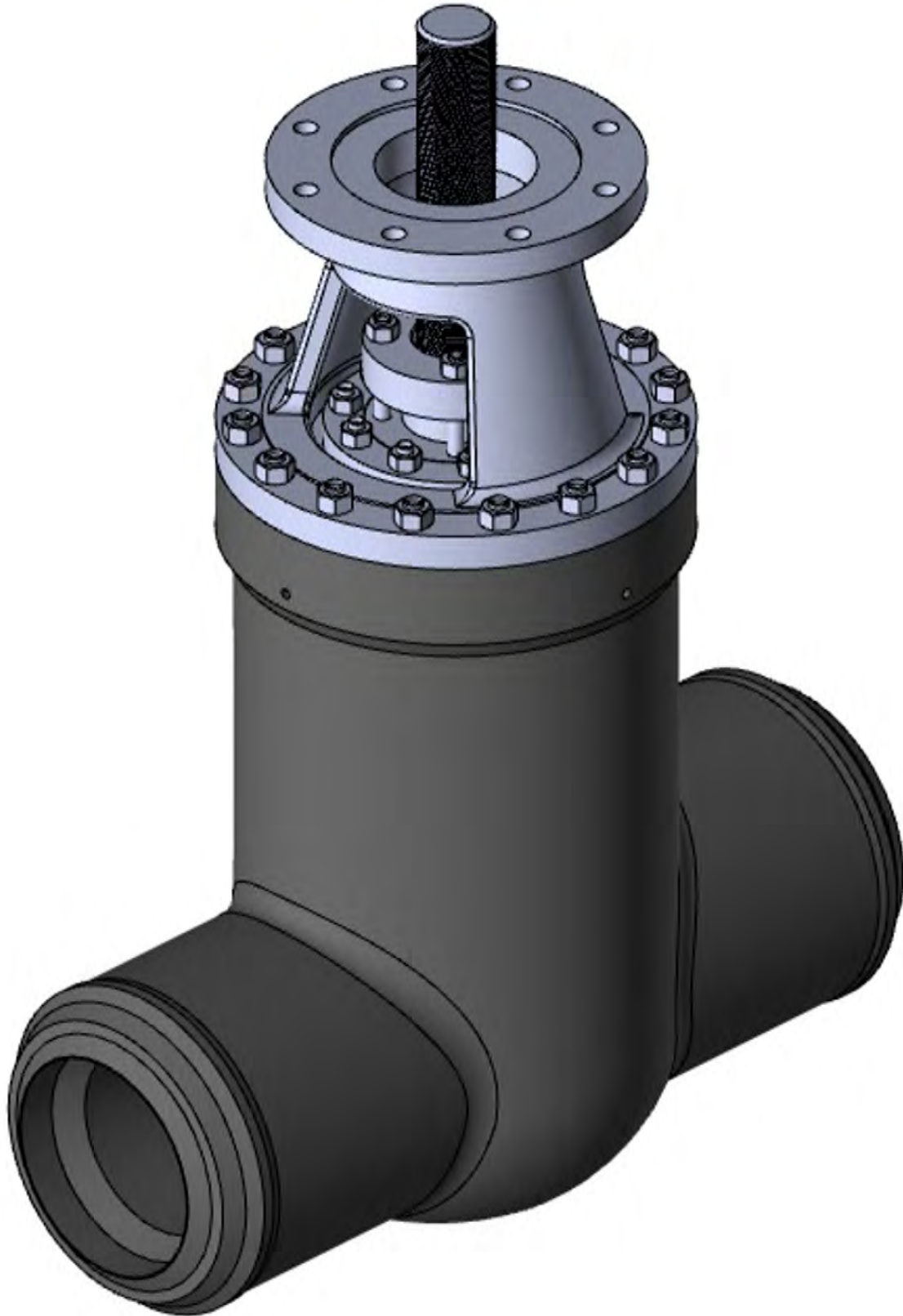

parallel slide/slab gate valve- B11

main features

Applicable Standards	Design according to ASME B16.34 or ASME VIII Div. 1 & 2
Pressure Class Range	ANSI Class 150 lbs. to 4500 lbs. API6A Class 3000 PSI to 20000 PSI
Size Range	From ½" to 42" Including from 1 13/16" to 13 5/8"
Ends Design	Flanged (RF – RTJ) – ASME B16.5, ASME B16.47 or MSS SP-44 Flanged (6B – 6BX) – API 6A Compact (i.e. Norsok Standard L-005) Butt-Weld (ASME B16.25) and/or Butt-Weld+Pipe Hubbed according to client Clamp Special client's requirements
Body Design	Single piece
Bonnet Design	Bolted bonnet or Pressure seal type
Trim Design	Metal to Metal (c/w hardfacing) non floating seat + Floating obturator
Valve Operation	Manual: Handwheel or Gearbox Actuated: Pneumatic / Hydraulic / Electric / Electro-Hydraulic
Available Materials	CS, LTCS, SS, Duplex SS, Super Duplex SS, 6Mo, Inconel, Incoloy, Hastelloy, Monel, Titanium NACE MR0175 according to client request
Additional Features	Bidirectional sealing independent from pressure and temperature variations, Metal to Metal Stem Backseat sealing, Graphite or V-Pack stem sealing arrangement, High CV value, Self-cleaning, In-line maintenance, other special client's requirements
Testing and Certification	Testing: Hydrostatic, High Pressure Gas, Pneumatic and Functional Special client's requirements API 598 Fire testing: API 6FA, API 607, BS 6755 part 2, ISO 10497 Fugitive Emission Test: ISO 15848 – 1 & 2 SIL Certificate up to SIL 3 PED 2014/68/UE Mod.H

through conduit double expanding gate valve

model B21

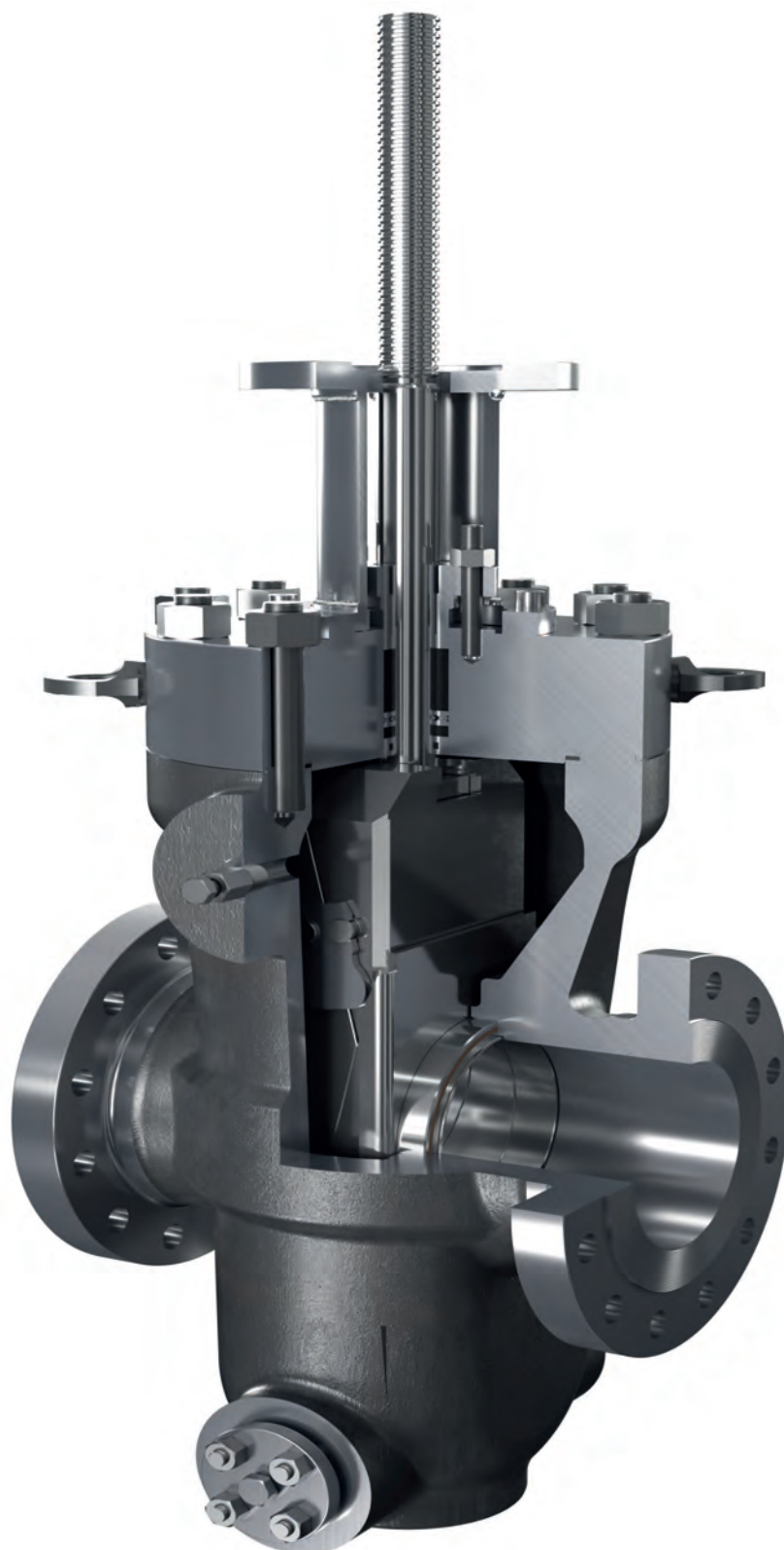

through conduit double expanding gate valve- B21

main features

Applicable standards	API 6D, API 6DSS and API 6A Design according to ASME B16.34 or ASME VIII Div. 1 & 2
Pressure Class Range	ANSI Class 150 lbs. to 4500 lbs. API6A Class 3000 PSI to 20000 PSI
Size Range	API 6D, API 6DSS - from ½" to 42" API 6A - from 1 13/16" to 13 5/8"
Ends design	Flanged (RF – RTJ) – ASME B16.5, ASME B16.47 or MSS SP-44 Flanged (6B – 6BX) – API 6A Compact (i.e. Norsok Standard L-005) Butt-Weld (ASME B16.25) and/or Butt-Weld+Pipe Hubbed according to client Clamp Special client's requirements
Body Design	Single piece
Bonnet Design	Bolted bonnet
Seat design	Non floating (without soft gasket) Metal to Metal (c/w hardfacing)
Valve operation	Manual: Handwheel or Gearbox Actuated: Pneumatic / Hydraulic / Electric / Electro-Hydraulic
Available Materials	CS, LTCS, SS, Duplex SS, Super Duplex SS, 6Mo, Inconel, Incoloy, Hastelloy, Monel, Titanium NACE MR0175 according to client request
Additional Features	Double Block and Bleed, Normal or Reverse acting, Graphite or V-Pack stem sealing arrangement
Testing and Certification	Testing: Hydrostatic, High Pressure Gas, Pneumatic and Functional API 598 – API 6D - API 6A PSL3G, API 6A PR2 & Endurance Fire testing: API 6FA, API 607, BS 6755 part 2, ISO 10497 Fugitive Emission Test: ISO 15848 – 1 & 2 SIL Certificate up to SIL 3 PED 2014/68/UE Mod.H Hyperbaric Test for Subsea application

swing check valve

model C11

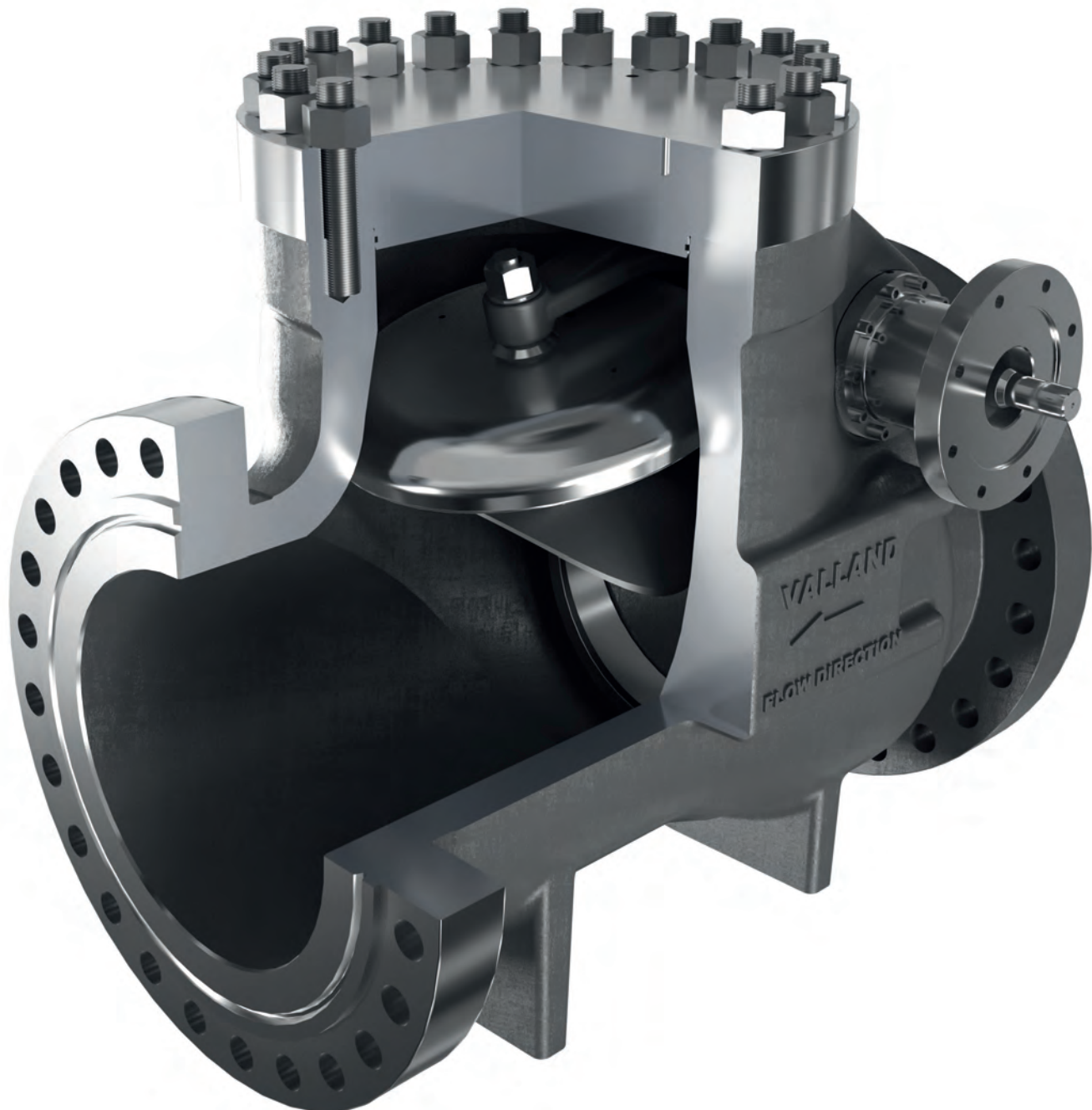

swing check valve- C11

main features

Applicable standards	API 6D and API 6DSS Design according to ASME B16.34 or ASME VIII Div. 1 & 2
Pressure Class Range	ANSI Class 150 lbs. to 4500 lbs.
Size Range	from ½" to 42"
Ends design	Flanged (RF – RTJ) – ASME B16.5, ASME B16.47 or MSS SP-44 Compact (i.e. Norsok Standard L-005) Butt-Weld (ASME B16.25) and/or Butt-Weld+Pipe Hubbed according to client Clamp Special client's requirements
Body Design	Single piece
Bonnet Design	Bolted bonnet
Seat design	Renewable or fixed Soft Sealing or Metal to Metal (c/w hardfacing)
Valve operation	Lockable Disc Option Available
Available Materials	CS, LTCS, SS, Duplex SS, Super Duplex SS, 6Mo, Inconel, Incoloy, Hastelloy, Monel, Titanium NACE MR0175 according to client request
Testing and Certification	Testing: Hydrostatic and Pneumatic API 598 – API 6D Fire testing: API 6FA, API 607, BS 6755 part 2, ISO 10497 Fugitive Emission Test: ISO 15848 – 1 & 2 PED 2014/68/UE Mod.H Hyperbaric Test for Subsea application

dual plate check valve

model C21



dual plate check valve- C21

main features

Applicable standards	API 6D Design according to ASME B16.34 or ASME VIII Div. 1 & 2
Pressure Class Range	ANSI Class 150 lbs. to 4500 lbs.
Size Range	from ½" to 42"
Ends design	Flanged (RF – RTJ) – ASME B16.5, ASME B16.47 or MSS SP-44 Compact (i.e. Norsok Standard L-005) Butt-Weld (ASME B16.25) and/or Butt-Weld+Pipe Hubbed according to client Clamp Special client's requirements
Body Design	Lugged – Wafer – Double Flanged
Seat Design	Integral Seat – Metal to Metal sealing
Stem Design	Retainer or Retainerless
Available Materials	CS, LTCS, SS, Duplex SS, Super Duplex SS, 6Mo, Inconel, Incoloy, Hastelloy, Monel, Titanium NACE MR0175 according to client request
Testing and Certification	Testing: Hydrostatic and Pneumatic API 598 – API 6D Fire testing: API 6FA, API 607, BS 6755 part 2, ISO 10497 Fugitive Emission Test: ISO 15848 – 1 & 2 PED 2014/68/UE Mod.H

side entry trunnion ball valve

model H11 – H2

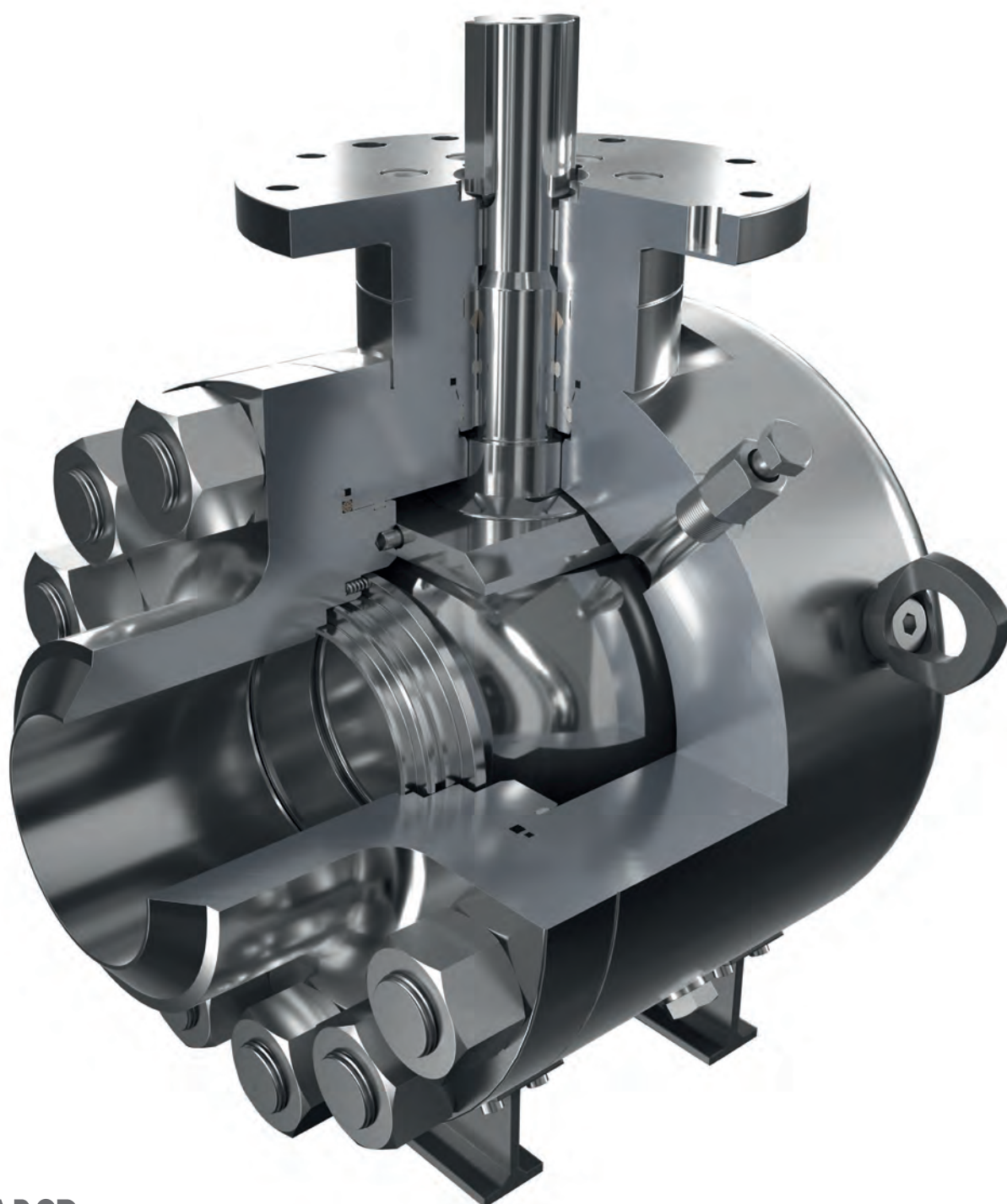

side entry trunnion ball valve- H11-H2

main features

Applicable standards	API 6D Design according to ASME B16.34 or ASME VIII Div. 1 & 2
Pressure Class Range	ANSI Class 150 lbs. to 4500 lbs.
Size Range	API 6D - from ½" to 42"
Ends design	Flanged (RF – RTJ) – ASME B16.5, ASME B16.47 or MSS SP-44 Flanged (6B – 6BX) – API 6A Compact (i.e. Norsok Standard L-005) Butt-Weld (ASME B16.25) and/or Butt-Weld+Pipe Hubbed according to client Clamp Special client's requirements
Body Design	Two Pieces
Closure Design	Bolted Closure or Fully welded
Ball support	Trunnion (small sizes < 4") – Support Plates
Seat design	Floating Self-Relieving – Floating Double Piston Effect Soft Sealing – Metal to Metal (c/w hardfacing)
Valve operation	Manual: Lever or Gearbox Actuated: Pneumatic / Hydraulic / Electric / Electro-Hydraulic
Available Materials	UNS S31600/3, UNS S31254, UNS S20910 and UNS S66286. Proper material selection verified by Valland material experts. NACE MR0175 according to client request
Additional Features	Double Block and Bleed, Double Isolation Barrier (DIB), Anti Blowout Stem, Antistatic Device, Special gasket to avoid contamination from environment
Testing and Certification	Testing: High Pressure Gas, Pneumatic and Functional Test in hydrogen environment according to client specifications API 598 – API 6D Fire testing: API 6FA, API 607, BS 6755 part 2, ISO 10497 Fugitive Emission Test: ISO 15848 – 1 & 2 SIL Certificate up to SIL 3 TR-CU PED 2014/68/UE Mod.H - UKCA - TSG (upon request)

side entry floating ball valve

model H21 – H2

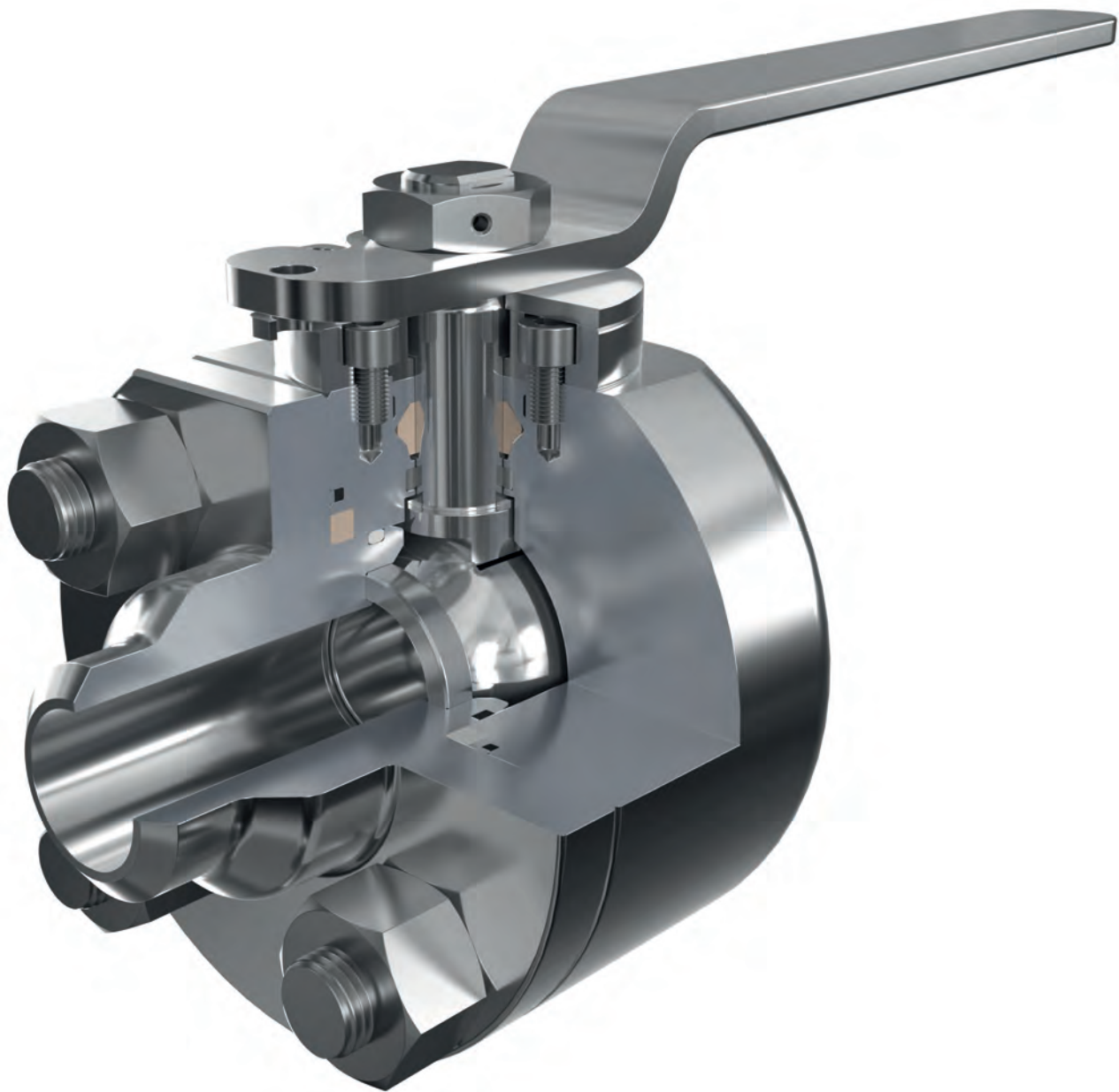

side entry floating ball valve- H21-H2

main features

Applicable standards	API 6D Design according to ASME B16.34 or ASME VIII Div. 1 & 2
Pressure Class Range	ANSI Class 150 lbs. to 1500 lbs.
Size Range	API 6D - from ½" to 8"
Ends design	Flanged (RF – RTJ) – ASME B16.5, ASME B16.47 or MSS SP-44 Compact (i.e. Norsok Standard L-005) Butt-Weld (ASME B16.25) and/or Butt-Weld+Pipe Hubbed according to client Clamp Special client's requirements
Body Design	Two Pieces
Closure Design	Bolted Closure or Fully welded
Seat design	Soft Sealing – Metal to Metal (c/w hardfacing)
Valve operation	Manual: Lever or Gearbox
Available Materials	UNS S31600/3, UNS S31254, UNS S20910 and UNS S66286. Proper material selection verified by Valland material experts. NACE MR0175 according to client request
Additional Features	Anti Blowout Stem, Antistatic Device Special gasket to avoid contamination from environment
Testing and Certification	Testing: High Pressure Gas, Pneumatic and Functional Test in hydrogen environment according to client specifications API 598 – API 6D Fire testing: API 6FA, API 607, BS 6755 part 2, ISO 10497 Fugitive Emission Test: ISO 15848 – 1 & 2 SIL Certificate up to SIL 3 TR-CU PED 2014/68/UE Mod.H - UKCA - TSG (upon request)